

**DIGITAL SUBSCRIBER LINE ACCESS SERVICE – ROCK HILL TELEPHONE COMPANY,
FORT MILL TELEPHONE COMPANY, LANCASTER TELEPHONE COMPANY AND
CITIZENS TELEPHONE COMPANY D/B/A COMPORIUM COMMUNICATIONS**

General Regulations

Definitions

Customer

Any individual, partnership, association, joint-stock company, trust, corporation, or governmental entity or other entity, which subscribes to the services offered under this service guide.

Digital Subscriber Line (DSL)

An access technology that allows simultaneous voice and high-speed data to be sent over local exchange service facilities.

Digital Subscriber Line (DSL) Access Service Connection Point

A location designated by the Telephone Company that serves as an aggregation point for the collection of Telephone Company DSL traffic from multiple Digital Subscriber Line Access Multiplexers (DSLAMs) or comparable packet-mode data modem equipment.

Downstream

The path from the Telephone Company's DSL Access Service Connection Point to the point of demarcation at the customer designated end user customer premises.

End User

Any customer of DSL service that is not a carrier, except that a carrier other than a telephone company shall be deemed to be an "end user" when such carrier uses a telecommunications service for administrative purposes, and a person or entity that offers telecommunications service exclusively as a reseller shall be deemed to be an "end user" if all resale transmissions offered by such reseller originate on the premises of such reseller.

Telephone Company

Rock Hill Telephone Company, Fort Mill Telephone Company or Lancaster Telephone Company.

Upstream

The transmission path from the point of demarcation at the customer end user premises to the DSL Access Service Connection Point.

Undertaking of the Telephone Company

Scope

The Telephone Company does not undertake to transmit messages under this service guide.

**DIGITAL SUBSCRIBER LINE ACCESS SERVICE – ROCK HILL TELEPHONE COMPANY,
FORT MILL TELEPHONE COMPANY, LANCASTER TELEPHONE COMPANY AND
CITIZENS TELEPHONE COMPANY D/B/A COMPORIUM COMMUNICATIONS**

The Telephone Company shall be responsible only for the installation, operation and maintenance of the services it provides.

The Telephone Company will, for maintenance purposes, test its service only to the extent necessary to detect and/or clear troubles.

Services are provided 24 hours daily, seven days per week, except as set forth in other applicable sections of this service guide.

The Telephone Company does not warrant that its facilities and services meet standards other than those set forth in this service guide.

The Telephone Company provides only those services that are contained in this service guide that the Telephone Company is technically capable of providing.

Limitations

Assignment or Transfer of Services

The customer may assign or transfer the use of services provided under this service guide only where there is no interruption of use or relocation of the services. Such assignment or transfer may be made to:

- another customer, whether an individual, partnership, association or corporation, provided the assignee or transferee assumes all outstanding indebtedness for such services, and the unexpired portion of the minimum period and the termination liability applicable to such services, if any; or
- a court-appointed receiver, trustee or other person acting pursuant to law in bankruptcy, receivership, reorganization, insolvency, liquidation or other similar proceedings, provided the assignee or transferee assumes the unexpired portion of the minimum period and the termination liability applicable to such services, if any.

In all cases of assignment or transfer, the written acknowledgement of the Telephone Company is required prior to such assignment or transfer. This acknowledgement shall be made within 15 days from the receipt of notification. All regulations and conditions contained in this service guide shall apply to such assignee or transferee.

The assignment or transfer of services does not relieve or discharge the assignor or transferor from remaining jointly or severally liable with the assignee or transferee for any obligations existing at the time of the assignment or transfer.

Use and Restoration of Services

The use and restoration of services shall be in accordance with Part 64, Subpart D, Appendix A, of the Federal Communications Commission's Rules and Regulations, which specifies the priority system for such activities.

Sequence of Provisioning

**DIGITAL SUBSCRIBER LINE ACCESS SERVICE – ROCK HILL TELEPHONE COMPANY,
FORT MILL TELEPHONE COMPANY, LANCASTER TELEPHONE COMPANY AND
CITIZENS TELEPHONE COMPANY D/B/A COMPORIUM COMMUNICATIONS**

Subject to compliance with the rules mentioned, the services offered herein will be provided to customers on a first-come, first-served basis.

The first-come, first-served sequence shall be based upon the received time and date recorded, by stamp or other notation, by the Telephone Company on customer access orders. These orders must contain all the information as required for each respective service as delineated in other sections of this service guide. Customer orders shall not be deemed to have been received until such information is provided. Should questions arise which preclude order issuance due to missing information or the need for clarification, the Telephone Company will attempt to seek such missing information or clarification on a verbal basis.

Liability

Limits of Liability

With respect to any other claim or suit, by a customer or by any others, for damages associated with the installation, provision, termination, maintenance, repair or restoration of service, and subject to the provisions following, the Telephone Company's liability if any, shall not exceed an amount equal to the proportionate charge for the service for the period during which the service was affected. This liability for damages shall be in addition to any amounts that may otherwise be due the customer under this service guide as a Credit Allowance for a Service Interruption.

Acts or Omissions

The Telephone Company shall not be liable for any act or omission of any other carrier or customer providing a portion of a service, nor shall the Telephone Company for its own act or omission hold liable any other carrier or customer providing a portion of a service.

Damages to Customer Premises

The Telephone Company is not liable for damages to the customer premises resulting from the furnishing of a service, including the installation and removal of equipment and associated wiring, unless the damage is caused by the Telephone Company's negligence.

Indemnification of the Telephone Company

By the End User

The Telephone Company shall be indemnified, defended and held harmless by the end user against any claim, loss or damage arising from the end user's use of services offered under this service guide, involving:

- claims for libel, slander, invasion of privacy, or infringement of copyright arising from the end user's own communications,

- claims for patent infringement arising from the end user's acts combining or using the service furnished by the Telephone Company in connection with facilities or equipment furnished by the end users or customer,

**DIGITAL SUBSCRIBER LINE ACCESS SERVICE – ROCK HILL TELEPHONE COMPANY,
FORT MILL TELEPHONE COMPANY, LANCASTER TELEPHONE COMPANY AND
CITIZENS TELEPHONE COMPANY D/B/A COMPORIUM COMMUNICATIONS**

-all other claims arising out of any act or omission of the end user in the course of using services provided pursuant to this service guide.

By the Customer

The Telephone Company shall be indemnified, defended and held harmless by the customer against any claim, loss or damage arising from the customer's use of services offered under this service guide, involving:

- claims for libel, slander, invasion of privacy, or infringement of copyright arising from the customer's own communications,
- claims for patent infringement arising from the customer's acts combining or using the service furnished by the Telephone Company in connection with facilities or equipment furnished by the end user or customer, or
- all other claims arising out of any act or omission of the customer in the course of using services provided pursuant to this service guide.

Explosive Atmospheres

The Telephone Company does not guarantee or make any warranty with respect to its services when used in an explosive atmosphere. The Telephone Company shall be indemnified, defended and held harmless by the customer from any and all claims by any person relating to such customer's use of services so provided.

No License Granted

No license under patents (other than the limited license to use) is granted by the Telephone Company or shall be implied or arise by estoppel, with respect to any service offered under this service guide. The Telephone Company will defend the customer against claims of patent infringement arising solely from the use by the customer of services offered under this service guide and will indemnify such customer for any damages awarded based solely on such claims.

Circumstances Beyond the Telephone Company's Control

The Telephone Company's failure to provide or maintain services under this service guide shall be excused by labor difficulties, governmental orders, civil commotions, criminal actions taken against the Telephone Company, acts of God and other circumstances beyond the Telephone Company's reasonable control, subject to the Credit Allowance for a Service Interruption as set forth following.

Provision of Services

The Telephone Company will provide to the customer, upon reasonable notice, services offered in other applicable sections of this service guide at rates and charges specified therein. Services will be made available to the extent that such services are or can be made available with reasonable effort, and after provision has been made for the Telephone Company's telephone exchange services.

Facility Terminations

**DIGITAL SUBSCRIBER LINE ACCESS SERVICE – ROCK HILL TELEPHONE COMPANY,
FORT MILL TELEPHONE COMPANY, LANCASTER TELEPHONE COMPANY AND
CITIZENS TELEPHONE COMPANY D/B/A COMPORIUM COMMUNICATIONS**

The services provided under this service guide will include any entrance cable or drop wiring and wire or intrabuilding cable to that point where provision is made for termination of the Telephone Company's outside distribution network facilities at a suitable location inside a customer-designated premises. Such wiring or cable will be installed by the Telephone Company to the Point of Termination. Moves of the Point of Termination at the customer designated premises will be as set forth following.

Service Maintenance

The services provided under this service guide shall be maintained by the Telephone Company. The customer or others may not rearrange, move, disconnect, remove or attempt to repair any facilities provided by the Telephone Company, other than by connection or disconnection to any interface means used, except with the written consent of the Telephone Company.

Changes and Substitutions

Except as provided for equipment and systems subject to FCC Part 68 Regulations at 47 C.F.R. Section 68.110(b), the Telephone Company may, where such action is reasonably required in the operation of its business, substitute, change or rearrange any facilities used in providing service under this service guide. Such actions may include, without limitation:

- substitution of different metallic facilities,
- substitution of carrier or derived facilities for metallic facilities used to provide other than metallic facilities,
- change of minimum protection criteria,
- change of operating or maintenance characteristics of facilities, or
- change of operations or procedures of the Telephone Company.

In case of any such substitution, change or rearrangement, the transmission parameters will be within the range as set forth following. The Telephone Company shall not be responsible if any such substitution, change or rearrangement renders any customer furnished services obsolete or requires modification or alteration thereof or otherwise affects their use or performance. If such substitution, change or rearrangement materially affects the operating characteristics of the facility, the Telephone Company will provide reasonable notification to the customer in writing. Reasonable time will be allowed for any redesign and implementation required by the change in operating characteristics. The Telephone Company will work cooperatively with the customer to determine reasonable notification procedures.

Reasons for Refusal and Discontinuance of Service

If a customer fails to comply with Service Maintenance or Damages, Availability for Testing, Balance, Jurisdictional Report and Certification Requirements, Payment of Rates, Charges or Deposits; or Connections, including any customer's failure to make payments on the date and times therein specified, the Telephone Company may, on thirty (30) calendar days written notice by Certified U.S. Mail, or overnight delivery to the person designated by that customer to receive such notices of noncompliance, take the following actions:

- refuse additional applications for service and/or refuse to complete any pending orders for service, and/or
- discontinue the provision of service to the customer.

In the case of discontinuance all applicable charges, including termination charges, shall become due.

**DIGITAL SUBSCRIBER LINE ACCESS SERVICE – ROCK HILL TELEPHONE COMPANY,
FORT MILL TELEPHONE COMPANY, LANCASTER TELEPHONE COMPANY AND
CITIZENS TELEPHONE COMPANY D/B/A COMPORIUM COMMUNICATIONS**

In addition to and not in limitation of the provisions above, if a customer fails to comply with regulations following, Payment of Rates, Charges and Deposits, including any payments to be made by it on the dates and times therein specified, the Telephone Company may take the actions specified above, with regard to services provided hereunder to that customer on fifteen (15) calendar days written notice to the person designated by that customer to receive such notices of noncompliance, such notice period to start the day after the notice is sent by overnight delivery, if the customer has not complied with respect to amounts due in a subject bill on subject deposit request and either:

- (1) the Telephone Company has sent the subject bill to the customer within seven (7) business days of the bill date; or
- (2) the Telephone Company has sent the subject bill to the customer more than thirty (30) calendar days before notice under this section is given; or
- (3) the Telephone Company has sent the subject deposit request to the customer more than fifteen (15) business days before notice under this section is given.

In all other cases, the Telephone Company will give thirty (30) calendar days written notice pursuant to the regulations above. The Telephone Company will maintain records sufficient to validate the date upon which a bill or deposit request was sent to the customer. Action specified above will not be taken with regard to the subject bill or subject deposit request if the customer cures the noncompliance prior to the expiration of the fifteen (15) or thirty (30) days notice period, as applicable.

The provisions above shall not apply to charges that a customer does not pay based on the submission of a good faith dispute pursuant to Billing Disputes regulations.

If a customer fails to comply with Unlawful and Abusive Use regulations following, the Telephone Company may, upon written request from a customer, or another exchange carrier, terminate service to any subscriber or customer identified as having utilized service provided under this service guide in the completion of abusive or unlawful telephone calls. Service shall be terminated by the Telephone Company as provided for in its general and/or local exchange service tariffs.

In such instances when termination occurs the Telephone Company shall be indemnified, defended and held harmless by any customer or Exchange Carrier requesting termination of service against any claim, loss or damage arising from the Telephone Company's actions in terminating such service, unless caused by the Telephone Company's negligence.

Except as provided for equipment or systems subject to the FCC Part 68 Rules in 47 C.F.R. Section 68.108, if the customer fails to comply with Interference or Impairment regulations, the Telephone Company will, where practicable, notify the customer that temporary discontinuance of the use of a service may be required; however, where prior notice is not practicable, the Telephone Company may temporarily discontinue service forthwith if such action is reasonable in the circumstances. In case of such temporary discontinuance, the customer will be notified promptly and afforded the opportunity to correct the condition, which gave rise to the temporary discontinuance. During such period of temporary discontinuance, credit allowance for service interruptions, is not applicable.

When access service is provided by more than one Telephone Company, the companies involved in providing the joint service may individually or collectively deny service to a customer for nonpayment. Where the Telephone Company(s) affected by the nonpayment is incapable of effecting discontinuance of service without cooperation from the other joint providers of Switched Access Service, such other Telephone Company(s) will, if technically feasible, assist in denying the joint service to the customer. Service denial for such joint service will only include calls originating or terminating within, or transiting,

**DIGITAL SUBSCRIBER LINE ACCESS SERVICE – ROCK HILL TELEPHONE COMPANY,
FORT MILL TELEPHONE COMPANY, LANCASTER TELEPHONE COMPANY AND
CITIZENS TELEPHONE COMPANY D/B/A COMPORIUM COMMUNICATIONS**

the operating territory of the Telephone Companies initiating the service denial for nonpayment. When more than one of the joint providers must deny service to effectuate termination for nonpayment, in cases where a conflict exists in the applicable service guide provisions, the service guide regulations of the end office Telephone Company shall apply for joint service discontinuance.

Notification of Service-Affecting Activities

The Telephone Company will provide the customer reasonable notification of service-affecting activities that may occur in the normal operation of its business. Such activities may include, but are not limited to the following:

- equipment or facilities additions;
- removals or rearrangements;
- routine preventative maintenance; and
- major switching machine change-out.

Generally, such activities are not individual customer service specific, but may affect many customer services. No specific advance notification period is applicable to all service activities. The Telephone Company will work cooperatively with the customer to determine reasonable notification requirements.

Coordination with Respect to Network Contingencies

The Telephone Company intends to work cooperatively with the customer to develop network contingency plans in order to maintain maximum network capability following natural or man-made disasters, which affect telecommunications services.

Provision and Ownership of Telephone Numbers

The Telephone Company reserves the reasonable right to assign, designate or change telephone numbers, any other call number designations associated with Access Services, or the Telephone Company serving central office prefixes associated with such numbers, when necessary in the conduct of its business. Should it become necessary to make a change in such number(s), the Telephone Company will furnish to the customer six (6) months' notice, by Certified U.S. Mail, of the effective date and an explanation of the reason(s) for such change(s).

Use

Interference or Impairment

The characteristics and methods of operation of any circuits, facilities or equipment provided by other than the Telephone Company and associated with the facilities utilized to provide services under this service guide shall not:

- interfere with or impair service over any facilities of the Telephone Company, its affiliated companies, or its connecting and concurring carriers involved in its services;
- cause damage to their plant;
- impair the privacy of any communications carried over their facilities; or

**DIGITAL SUBSCRIBER LINE ACCESS SERVICE – ROCK HILL TELEPHONE COMPANY,
FORT MILL TELEPHONE COMPANY, LANCASTER TELEPHONE COMPANY AND
CITIZENS TELEPHONE COMPANY D/B/A COMPORIUM COMMUNICATIONS**

-create hazards to the employees of any of them or the public.

Unlawful and Abusive Use

The service provided under this service guide shall not be used for an unlawful purpose or used in an abusive manner.

Abusive use includes:

-the use of the service of the Telephone Company for a call or calls, anonymous or otherwise, in a manner reasonably expected to frighten, abuse, torment, or harass another;

-the use of the service in such a manner as to interfere unreasonably with the use of the service by one or more other customers.

Obligations of the Customer

Damages

The customer shall reimburse the Telephone Company for damages to Telephone Company facilities utilized to provide services under this service guide caused by the negligence or willful act of the customer or resulting from the customer's improper use of the Telephone Company facilities, or due to malfunction of any facilities or equipment provided by other than the Telephone Company. Nothing in the foregoing provision shall be interpreted to hold one customer liable for another customer's actions. The Telephone Company will, upon reimbursement for damages, cooperate with the customer in prosecuting a claim against the person causing such damage and the customer shall be subrogated to the right of recovery by the Telephone Company for the damages to the extent of such payment.

Ownership of Facilities and Theft

Facilities utilized by the Telephone Company to provide service under the provisions of this service guide shall remain the property of the Telephone Company. Such facilities shall be returned to the Telephone Company by the customer, whenever requested, within a reasonable period. The equipment shall be returned in as good condition as reasonable wear will permit.

Equipment Space and Power

The customer shall furnish or arrange to have furnished to the Telephone Company, at no charge, equipment space and electrical power required by the Telephone Company to provide services under this service guide at the points of termination of such services. The selection of AC or DC power shall be mutually agreed to by the customer and the Telephone Company. The customer shall also make necessary arrangements in order that the Telephone Company will have access to such spaces at reasonable times for installing, testing, repairing or removing Telephone Company facilities used to provide services.

Availability for Testing

Access to facilities used to provide services under this service guide shall be available to the Telephone Company at times mutually agreed upon in order to permit the Telephone Company to make tests and adjustments appropriate for maintaining the services in satisfactory operating condition. Such tests and

**DIGITAL SUBSCRIBER LINE ACCESS SERVICE – ROCK HILL TELEPHONE COMPANY,
FORT MILL TELEPHONE COMPANY, LANCASTER TELEPHONE COMPANY AND
CITIZENS TELEPHONE COMPANY D/B/A COMPORIUM COMMUNICATIONS**

adjustments shall be completed within a reasonable time. As set forth following, no credit will be allowed for any interruptions involved during such tests and adjustments.

Limitation of Use of Metallic Facilities

Signals applied to a metallic facility shall conform to the limitations set forth in Technical Reference Publication AS No. 1. In the case of application of DC telegraph signaling systems, the customer shall be responsible, at its expense, for the provision of current limiting devices to protect the Telephone Company facilities from excessive current due to abnormal conditions and for the provision of noise mitigation networks when required to reduce excessive noise.

Balance

All signals for transmission over the facilities used to provide services under this service guide shall be delivered by the customer balanced to ground except for ground start, duplex (DX) and McCulloch-Loop (Alarm System) type signaling and DC telegraph transmission at speeds of 75 baud or less.

Design of Customer Services

Subject to the provisions of Changes and Substitutions, the customer shall be solely responsible, at its own expense, for the overall design of its services and for any redesigning or rearrangement of its services which may be required because of changes in facilities, operations or procedures of the Telephone Company, minimum protection criteria or operating or maintenance characteristics of the facilities.

References to the Telephone Company

The customer may advise end users that certain services are provided by the Telephone Company in connection with the service the customer furnishes to end users; however, the customer shall not represent that the Telephone Company jointly participates in the customer's services.

Claims and Demands for Damages

- (A) With respect to claims of patent infringement made by third persons, the customer shall defend, indemnify, protect and save harmless the Telephone Company from and against all claims arising out of the combining with, or use in connection with, the services provided under this service guide, any circuit, apparatus, system or method provided by the customer.
- (B) The customer shall defend, indemnify and save harmless the Telephone Company from and against any suits, claims, losses and damages, including punitive damages, attorney fees and court costs by third persons arising out of the construction, installation, operation, maintenance, or removal of the customer's circuits, facilities, or equipment connected to the Telephone Company's services provided under this service guide including, without limitation, Worker's Compensation claims, actions for infringement of copyright and/or unauthorized use of program material, libel and slander actions based on the content of communications transmitted over the customer's circuits, facilities or equipment, and proceedings to recover taxes, fines, or penalties for failure of the customer to obtain or maintain in effect any necessary certificates, permits, licenses, or other authority to acquire or operate the services provided under this service guide; provided, however, the foregoing indemnification shall not apply to suits, claims, and demands to recover damages for damage to property, death, or personal injury unless such suits, claims or demands are based on the tortious conduct of the customer, its officers, agents or employees.

**DIGITAL SUBSCRIBER LINE ACCESS SERVICE – ROCK HILL TELEPHONE COMPANY,
FORT MILL TELEPHONE COMPANY, LANCASTER TELEPHONE COMPANY AND
CITIZENS TELEPHONE COMPANY D/B/A COMPORIUM COMMUNICATIONS**

- (C) The customer shall defend, indemnify and save harmless the Telephone Company from and against any suits, claims, losses or damages, including punitive damages, attorney fees and court costs by the customer or third parties arising out of any act of omission of the customer in the course of using services provided under this service guide.

Coordination with Respect to Network Contingencies

The customer shall, in cooperation with the Telephone Company, coordinate in planning the actions to be taken to maintain maximum network capability following natural or man-made disasters, which affect telecommunications, services.

Payment of Rates, Charges and Deposits

Deposits

The Telephone Company will only require a customer that has a proven history of late payments to the Telephone Company or that does not have established credit, to make a deposit as a guarantee of the payment of rates and charges. Such deposit may be required prior to establishing a service or at any time after the provision of a service to the customer.

For purposes of this section, a proven history of late payments is defined as two (2) or more occasions within the preceding twelve (12) months in which payment for undisputed charges was not received within three (3) business days following the payment due date, provided the outstanding undisputed amount of each such individual unpaid bill represented at least ten (10) percent of the total charges on that individual bill. The Telephone Company will provide notice via overnight delivery to the person designated by the customer to receive such notice of the requirement to pay a deposit. The customer will be required to make payment of such deposit prior to the provision of service in those cases where the customer has not established credit with the Telephone Company, or otherwise within fifteen (15) business days of such notice. Such notice period will start the day after the notice is sent by overnight delivery.

No such deposit will be required of a customer which is a successor of a company which has established credit and has no history of late payments to the Telephone Company. For new service(s) being established, such deposit will not exceed the estimated rates and charges for a two-month period. For existing services, such deposit will not exceed the actual rates and charges for a two (2) month period associated with each individual bill that met the criteria for late payments specified above. The fact that a deposit has been made in no way relieves the customer from complying with the Telephone Company's regulations as to the prompt payment of bills. At such time as the provision of the service to the customer is terminated, the amount of the deposit will be credited to the customer's account and any credit balance, which may remain, will be refunded.

Such a deposit will be refunded or credited to the account when the customer has established credit or, in any event, after the customer has established a one-year prompt payment record at any time prior to the termination of the provision of the service to the customer. In case of a cash deposit, for the period the deposit is held by the Telephone Company, the customer will receive interest at the same percentage rate as that set forth following, whichever is lower.

The rate will be compounded daily for the number of days from the date the customer deposit is received by the Telephone Company to and including the date such deposit is credited to the customer's account or

**DIGITAL SUBSCRIBER LINE ACCESS SERVICE – ROCK HILL TELEPHONE COMPANY,
FORT MILL TELEPHONE COMPANY, LANCASTER TELEPHONE COMPANY AND
CITIZENS TELEPHONE COMPANY D/B/A COMPORIUM COMMUNICATIONS**

the date the deposit is refunded by the Telephone Company. Should a deposit be credited to the customer's account, as indicated above, no interest will accrue on the deposit from the date such deposit is credited to the customer's account.

Bill Dates

The Telephone Company shall bill on a current basis all charges incurred by and credits due to the customer under this service guide attributable to services established or discontinued during the preceding billing period. In addition, the Telephone Company shall bill in advance charges for all services to be provided during the ensuing billing period except for charges associated with service usage and for the Federal Government which will be billed in arrears. The bill day (i.e., the billing date of a bill for a customer for Access Service under this service guide), the period of service each bill covers and the payment date will be as follows:

End User Access Service and Presubscription

For End User Access Service and Presubscription Service, the Telephone Company will establish a bill day each month for each end user account or advise the customer in writing of an alternate billing schedule. Alternate billing schedules shall not be established on less than 60 days notice or initiated by the Telephone Company more than twice in any consecutive 12 month period. The bill will cover End User Access Service charges for the ensuing billing period except for End User Access Service for the Federal Government, which will be billed in arrears. Any applicable Presubscription Charges, any known unbilled charges for prior periods and any known unbilled adjustments for prior periods for End User Access Service and Presubscription Service will be applied to this bill. Such bills are due when rendered.

Access Services Other Than End User and Presubscription

For Service other than End User Access Service and Presubscription Service, the Telephone Company will establish a bill day each month for each customer account or advise the customer in writing of an alternate billing schedule. Alternate billing schedules shall not be established on less than 60 days' notice or initiated by the Telephone Company more than twice in any consecutive 12 month period.

The bill will cover nonusage sensitive service charges for the ensuing billing period for which the bill is rendered, any known unbilled nonusage sensitive charges for prior periods and unbilled usage charges for the period after the last bill day through the current bill day. Any known unbilled usage charges for prior periods and any known unbilled adjustments will be applied to this bill. Payment for such bills is due in immediately available funds by the payment date. If payment is not received by the payment date, a late payment penalty will apply.

Payment Dates and Late Payment Penalties

- (1) All bills dated as set forth preceding for service, other than End User Service and Presubscription Service, provided to the customer by the Telephone Company are due 31 days (payment date) after the bill day or by the next bill date (i.e., same date in the following month as the bill date), whichever is the shortest interval, except as provided herein, and are payable in immediately available funds. If the customer does not receive a bill at least 20 days prior to the 31-day payment due date, then the bill shall be considered delayed. When the bill has been delayed, upon request of the customer the due date will be extended by the number of days the bill was delayed. Such request of the customer must be accompanied with proof of late bill receipt.

**DIGITAL SUBSCRIBER LINE ACCESS SERVICE – ROCK HILL TELEPHONE COMPANY,
FORT MILL TELEPHONE COMPANY, LANCASTER TELEPHONE COMPANY AND
CITIZENS TELEPHONE COMPANY D/B/A COMPORIUM COMMUNICATIONS**

If such payment date would cause payment to be due on a Saturday, Sunday or Legal Holiday, payment for such bills will be due from the customer as follows:

- If the payment date falls on a Sunday or on a Legal Holiday, which is observed on a Monday, the payment date shall be the first non-Holiday day following such Sunday or Legal Holiday.
 - If the payment date falls on a Saturday or on a Legal Holiday, which is observed on Tuesday, Wednesday, Thursday or Friday, the payment date shall be the last non-Holiday day preceding such Saturday or Legal Holiday.
- (2) Further, if no payment is received by the payment date or if a payment or any portion of a payment is received by the Telephone Company after the payment date as set forth in (1) preceding, or if a payment or any portion of a payment is received by the Telephone Company in funds which are not immediately available to the Telephone Company, then a late payment penalty shall be due to the Telephone Company. The late payment penalty shall be the payment or the portion of the payment not received by the payment date times a late factor. The late factor shall be the lesser of:
- (a) the highest interest rate (in decimal value) which may be levied by law for commercial transactions, compounded daily for the number of days from the payment date to and including the date that the customer actually makes the payment to the Telephone Company, or
 - (b) 0.000292 per day, compounded daily for the number of days from the payment date to and including the date that the customer actually makes the payment to the Telephone Company.

Billing Disputes

A good faith dispute requires the customer to provide a written claim to the Telephone Company. Instructions for submitting a dispute can be obtained by calling the billing inquiry number shown on the customer's bill, or, when available, by accessing such information on the Telephone Company's website also shown on the customer's bill. Such claim must identify in detail the basis for the dispute, and if the customer withholds the disputed amounts, it must identify the account number under which the bill has been rendered, the date of the bill, and the specific items on the bill being disputed to permit the Telephone Company to investigate the merits of the dispute.

The date of the dispute shall be the date on which the customer furnishes the Telephone Company the account information required above.

The date of resolution is the date the Telephone Company completes its investigation, provides written notice to the customer regarding the disposition of the claim, i.e., resolved in favor of the customer or resolved in favor of the Telephone Company, and credits the customer's account, if applicable.

In the event that a billing dispute concerning any charges billed to the customer by the Telephone Company is resolved in favor of the Telephone Company, any payments withheld pending settlement of the dispute shall be subject to the late payment penalty set forth above.

**DIGITAL SUBSCRIBER LINE ACCESS SERVICE – ROCK HILL TELEPHONE COMPANY,
FORT MILL TELEPHONE COMPANY, LANCASTER TELEPHONE COMPANY AND
CITIZENS TELEPHONE COMPANY D/B/A COMPORIUM COMMUNICATIONS**

If the customer pays the bill in full by the payment due date, and later initiates a billing dispute within ninety (90) days of the payment due date, penalty interest may be applicable.

If the billing dispute is resolved in favor of the customer, the customer shall receive a credit from the Telephone Company. This credit will be an amount equal to the disputed amount resolved in the customer's favor times a penalty factor. This amount will apply from the date of the customer's payment through the date on which the customer receives the disputed amount credit from the Telephone Company. The penalty factor shall be the lesser of:

- (i) the highest interest rate (in decimal value) which may be levied by law for commercial transactions, compounded daily for the number of days from the first date to and including the last date of the period involved, or
- (ii) 0.000292 per day, compounded daily for the number of days from the first date to and including the last date of the period involved.

If the dispute is resolved in favor of the Telephone Company, a late payment charge and/or a penalty interest charge may be applicable.

If the customer pays the bill in full by the payment due date, and later initiates a billing dispute after (90) days of the payment due date, penalty interest may be applicable.

If the billing dispute is resolved in favor of the customer, the customer shall receive a credit from the Telephone Company. This credit will be an amount equal to the disputed amount resolved in the customer's favor times a penalty factor. This amount will apply from the date of the dispute through the date on which the customer receives the disputed amount credit from the Telephone Company. The penalty factor shall be the lesser of:

- (i) the highest interest rate (in decimal value) which may be levied by law for commercial transactions, compounded daily for the number of days from the first date to and including the last date of the period involved, or
- (ii) 0.000292 per day, compounded daily for the number of days from the first date to and including the last date of the period involved.

If the dispute is resolved in favor of the Telephone Company, a late payment charge and/or a penalty interest charge may be applicable.

Proration of Charges

Adjustments for the quantities of services established or discontinued in any billing period beyond the minimum period set forth for services in other sections of this service guide will be prorated to the number of days based on a 30 day month. The Telephone Company will, upon request, furnish within 30 days of a request and at no charge to the customer such detailed information as may reasonably be required for verification of any bill.

Rounding of Charges

**DIGITAL SUBSCRIBER LINE ACCESS SERVICE – ROCK HILL TELEPHONE COMPANY,
FORT MILL TELEPHONE COMPANY, LANCASTER TELEPHONE COMPANY AND
CITIZENS TELEPHONE COMPANY D/B/A COMPORIUM COMMUNICATIONS**

When a rate as set forth in this service guide is shown to more than two decimal places, the charges will be determined using the rate shown. The resulting amount will then be rounded to the nearest penny (i.e., rounded to two decimal places).

Minimum Periods

The minimum period for which service is provided and for which rates and charges are applicable for a Specialized Service or Arrangement provided on an individual case basis as set forth following, is one month unless a different minimum period is established with the individual case filing.

When a service is discontinued prior to the expiration of the minimum period, charges are applicable, whether the service is used or not, as follows:

- (A) When a service with a one-month minimum period is discontinued prior to the expiration of the minimum period, a one-month charge will apply at the rate level in effect at the time service is discontinued.
- (B) When a service with a minimum period greater than one month is discontinued prior to the expiration of the minimum period, the applicable charge will be the lesser of (1) the Telephone Company's total nonrecoverable costs less the net salvage value for the discontinued service or (2) the total monthly charges, at the rate level in effect at the time service is discontinued, for the remainder of the minimum period.

Cancellation of an Order for Service

Provisions for the cancellation of an order for service are set forth in other applicable sections of this service guide.

Credit Allowance for Service Interruptions

A service is interrupted when it becomes unusable to the customer because of a failure of a facility component used to furnish service under this service guide or in the event that the protective controls applied by the Telephone Company result in the complete loss of service by the customer. An interruption period starts when an inoperative service is reported to the Telephone Company, and ends when the service is operative.

When a Credit Allowance Applies

In case of an interruption to any service, allowance for the period of interruption, if not due to the negligence of the customer, shall be provided.

No credit shall be allowed for an interruption of less than 30 minutes. The customer shall be credited for an interruption of 30 minutes or more at the rate of 1/1440 of the monthly charges for the facility or service for each period of 30 minutes or Major Fraction Thereof that the interruption continues.

The credit allowance(s) for an interruption or for a series of interruptions shall not exceed any monthly rate for the service interrupted in any 1 monthly billing period.

When a Credit Allowance Does Not Apply

No credit allowance will be made for:

**DIGITAL SUBSCRIBER LINE ACCESS SERVICE – ROCK HILL TELEPHONE COMPANY,
FORT MILL TELEPHONE COMPANY, LANCASTER TELEPHONE COMPANY AND
CITIZENS TELEPHONE COMPANY D/B/A COMPORIUM COMMUNICATIONS**

Interruptions caused by the negligence of the customer;

Interruptions of a service due to the failure of equipment or systems provided by the customer or others;

Interruptions of a service during any period in which the Telephone Company is not afforded access to the premises where the service is terminated;

Interruptions of a service when the customer has released that service to the Telephone Company for maintenance purposes, to make rearrangements, or for the implementation of an order for a change in the service during the time that was negotiated with the customer prior to the release of that service.

Thereafter, a credit allowance as set forth preceding applies,

- interruptions of a service which continue because of the failure of the customer to authorize replacement of any element of special construction, as set forth in NATIONAL EXCHANGE CARRIER ASSOCIATION, INC. TARIFF F.C.C. NO. 3 for SPECIAL CONSTRUCTION. The period for which no credit allowance is made begins on the seventh day after the customer receives the Telephone Company's written notification of the need for such replacement and ends on the day after receipt by the Telephone Company of the customer's written authorization for such replacement;
- periods when the customer elects not to release the service for testing and/or repair and continues to use it on an impaired basis; or
- An interruption or a group of interruptions, resulting from a common cause, which would result in credit in an amount less than one dollar.
- Use of an Alternative Service Provided by the Telephone Company.

Should the customer elect to use an alternative service provided by the Telephone Company during the period that a service is interrupted, the customer must pay the rates and charges for the alternative service used.

Temporary Surrender of a Service

In certain instances, the customer may be requested by the Telephone Company to surrender a service for purposes other than maintenance, testing or activity relating to a service order. If the customer consents, a credit allowance will be granted. The credit allowance will be 1/1440 of the monthly rate for each period of 30 minutes or fraction thereof that the service is surrendered. In no case will the credit allowance exceed the monthly rate for the service surrendered in any one monthly billing period.

Re-establishment of Service Following Fire, Flood or Other Occurrence

Charges do not apply for the re-establishment of service following a fire, flood or other occurrence attributed to an Act of God provided that:

- (1) The service is of the same type as was provided prior to the fire, flood or other occurrence.
- (2) The service is for the same customer.
- (3) The service is at the same location on the same premises.

**DIGITAL SUBSCRIBER LINE ACCESS SERVICE – ROCK HILL TELEPHONE COMPANY,
FORT MILL TELEPHONE COMPANY, LANCASTER TELEPHONE COMPANY AND
CITIZENS TELEPHONE COMPANY D/B/A COMPORIUM COMMUNICATIONS**

- (4) The re-establishment of service begins within 60 days after Telephone Company service is available. (The 60 day period may be extended a reasonable period if the renovation of the original location on the premises affected is not practical within the allotted time period).

Nonrecurring Charges apply for establishing service at a different location on the same premises or at a different premises pending re-establishment of service at the original location.

Title or Ownership Rights

The payment of rates and charges by customers for the services offered under the provisions of this service guide does not assign, confer or transfer title or ownership rights to proposals or facilities developed or utilized, respectively, by the Telephone Company in the provision of such services.

Connections

Equipment and Systems (i.e., terminal equipment, multiline terminating systems and communications systems) may be connected with Switched and Special Access Service furnished by the Telephone Company where such connection is made in accordance with the provisions specified in Technical Reference Publication AS No. 1 regulations preceding.

Digital Subscriber Line (DSL) Access Service Regulations

Digital Subscriber Line (DSL) Access Service is a high-speed data access service that is made available to Network Service Providers for provision of high speed data services to their customers. DSL Access Service is provided to the customer through connection to the Telephone Company DSL Access Service Connection Point. Connections to the DSL Access Service Connection Point may be available through a Telephone Company's Asynchronous Transfer Mode (ATM) connection or a Telephone Company High Capacity DSL Access Connection. Rates and charges for Asynchronous Transfer Mode and High Capacity Access services are found in JOHN STAURULAKIS, INC. F.C.C. TARIFF NO. 1.

DSL Access Service transports data traffic generated by a customer-provided DSL modem from and to the end user customer's Network Interface Device (NID) to and from the Telephone Company's DSL Access Service Connection Point over existing Telephone Company local exchange service loops. To and from the DSL Access Service Connection Point, the traffic is transported from or to the customer's Network Service Provider via one of the methods described hereunder. The method or methods available from the Telephone Company offering DSL under this service guide are indicated following.

**DIGITAL SUBSCRIBER LINE ACCESS SERVICE – ROCK HILL TELEPHONE COMPANY,
FORT MILL TELEPHONE COMPANY, LANCASTER TELEPHONE COMPANY AND
CITIZENS TELEPHONE COMPANY D/B/A COMPORIUM COMMUNICATIONS**

Telephone Company ATM Network

The Telephone Companies also offer ATM-CRS Access Service for the transport of Network Service Provider traffic between the Network Service Provider's designated premises and the DSL Access Service Connection Point through Special Access High Capacity Services connected to Telephone Company ATM-CRS Access Service NNI Port ⁽¹⁾ at the Telephone Company's DSL Access Connection Point enabled for UBR or VBR transmission. There are no additional charges for individual Virtual Paths or Virtual Circuits associated with the provision of DSL Access Service.

Telephone Company High Capacity DSL Access Connection

The designated end user premises location must be served by an existing Telephone Company provided exchange line facility. An exchange line facility is the serving wire center central office line equipment and all of the plant facilities up to and including the Telephone Company-provided NID.

The connection speed or "sync rate" is between the NID at the end user's premises and the DSLAM. Actual data transfer or throughput may be lower than the sync-rate due to Internet congestion, server or router speeds, protocol overheads, end user use of multiple applications and other factors that may not be under the Telephone Company's control.

DSL Access Service will be provided subject to the availability and limitations of the Telephone Company Wire Centers and outside plant facilities. Actual speed may be affected by loop distance and other factors.

**DIGITAL SUBSCRIBER LINE ACCESS SERVICE – ROCK HILL TELEPHONE COMPANY,
FORT MILL TELEPHONE COMPANY, LANCASTER TELEPHONE COMPANY AND
CITIZENS TELEPHONE COMPANY D/B/A COMPORIUM COMMUNICATIONS**

The following diagram depicts a generic view of the components of DSL provided in combination with an ATM-CRS Network-to-Network Interface (NNI) Port

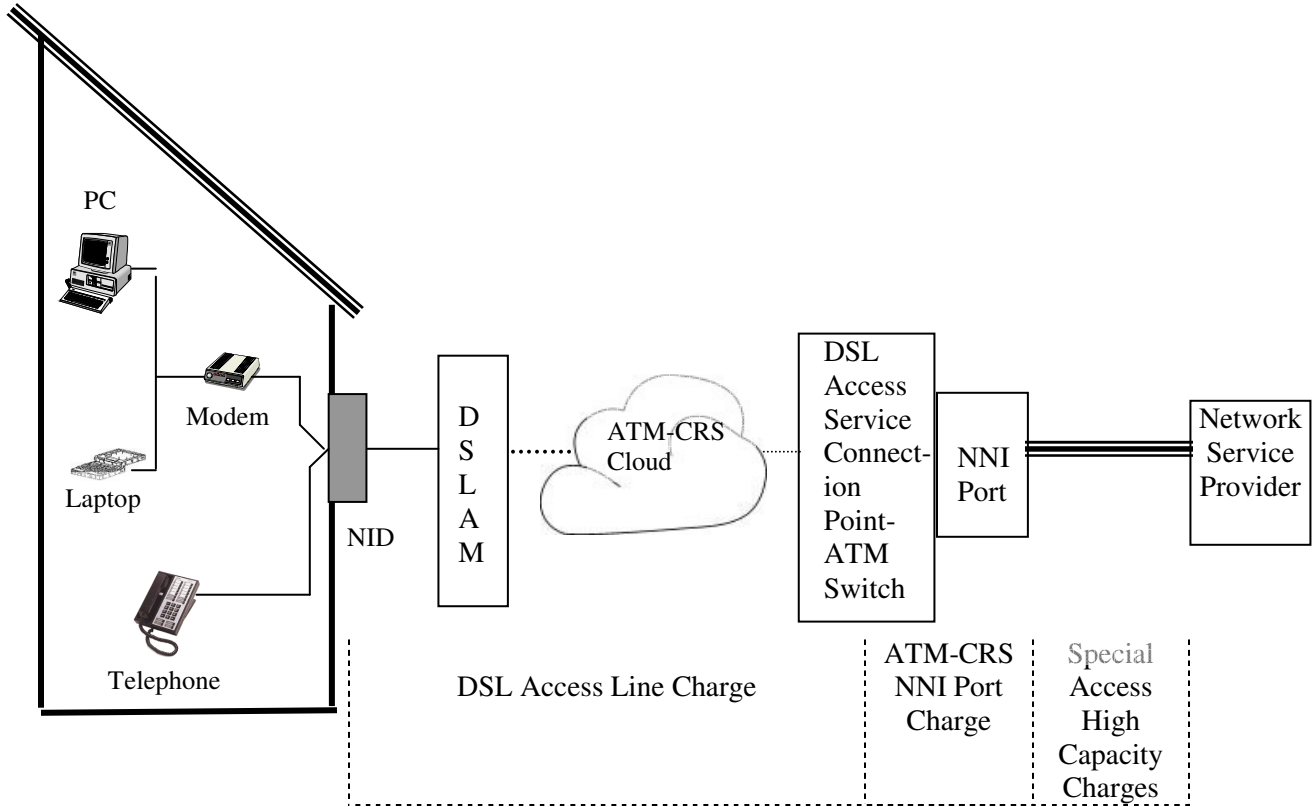

Monthly Recurring Charges

DSL Access Line Charges for each end user connection. ATM-CRS NNI Port Charge.

Special Access High Capacity Charges:

for a Network Service Provider customer designated premises within the Telephone Company wire center in which DSL Access Connection Point is located, Channel Termination charge or charges apply.

for a Network Service Provider customer designated premises outside of the Telephone Company wire center in which the DSL Access Connection Point is located, Channel Mileage (Channel Mileage Termination and Channel Mileage Facility) apply.

In addition to other appropriate nonrecurring charges associated with each of the above rate elements, an ATM-CRS DSL Access Service Connection nonrecurring charge applies.

**DIGITAL SUBSCRIBER LINE ACCESS SERVICE – ROCK HILL TELEPHONE COMPANY,
FORT MILL TELEPHONE COMPANY, LANCASTER TELEPHONE COMPANY AND
CITIZENS TELEPHONE COMPANY D/B/A COMPORIUM COMMUNICATIONS**

The following diagram depicts a generic view of the components of DSL provided in combination with Special Access High Capacity DSL Access Connection Service.

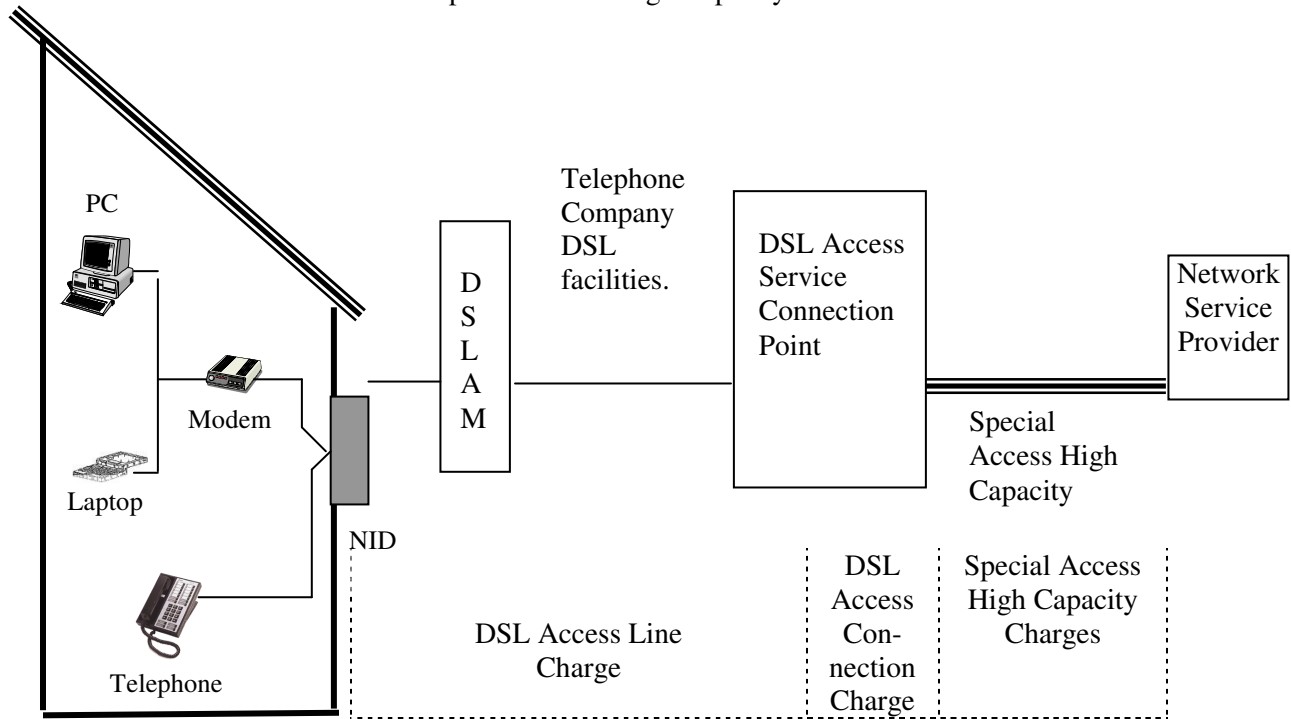

Monthly Recurring Charges

DSL Access Line Charges for each end user connection. ATM-CRS NNI Port Charge.

Special Access High Capacity Charges:

for a Network Service Provider customer designated premises within the Telephone Company wire center in which DSL Access Connection Point is located, Channel Termination charge or charges would apply.

for a Network Service Provider customer designated premises outside of the Telephone Company wire center in which the DSL Access Connection Point is located, Channel Mileage (Channel Mileage Termination and Channel Mileage Facility) charges would apply.

In addition to other appropriate nonrecurring charges associated with each of the above rate elements, an ATM-CRS DSL Access Service Connection nonrecurring charge applies

DSL Provisioning

Responsibility of the Telephone Company

DSL Access Service will be provisioned over existing Telephone Company local exchange service lines or copper facilities.

The Telephone Company will determine if the associated local exchange service line or copper facilities are suitable for use with the DSL Access Service option ordered by the customer. Service will not be

**DIGITAL SUBSCRIBER LINE ACCESS SERVICE – ROCK HILL TELEPHONE COMPANY,
FORT MILL TELEPHONE COMPANY, LANCASTER TELEPHONE COMPANY AND
CITIZENS TELEPHONE COMPANY D/B/A COMPORIUM COMMUNICATIONS**

provided on lines that are not suitable for DSL Access Service or on lines that produce interference with other services provided by the Telephone Company.

The Telephone Company will provision and maintain DSL Access Service for the customer between the NID at the end user premises and the customer's ATM-CRS NNI Port or Special Access High Capacity DSL Access Connection Point.

The Telephone Company reserves the right to temporarily interrupt DSL Access Service for wire center or network maintenance, software updates, and in emergency situations.

The Telephone Company will automatically disconnect DSL Access Service when the associated local exchange service line is disconnected for any reason.

Responsibility of the Customer

The customer is responsible for obtaining and installing compatible customer premises equipment (DSL modems and/or routers) used for connection to Telephone Company DSL Access Service.

The customer is responsible for ensuring the continuing compatibility of CPE at the end user premises. The customer and/or end user shall be responsible for any expenses incurred for required changes to customer and/or end user equipment or facilities in order to make such equipment or facilities compatible with Telephone Company DSL Access Service.

The customer is responsible for providing the Telephone Company with the necessary information to provision the DSL Access Service to its subscribers.

The customer ordering DSL Access Service on behalf of its subscriber(s) must obtain and maintain record of a letter of agency authorizing the customer to act as the agent of the end user subscriber. Upon request from the Telephone Company, the customer will provide the Telephone Company with a copy of the letter of agency.

The customer must have connectivity to Telephone Company's ATM-CRS or Special Access High Capacity Service network where customer chooses to purchase DSL Access Service. The rates and charges for ATM Service or Special Access High Capacity Service are in addition to the rates and charges for DSL Access Service.

The customer will obtain the appropriate authorization to allow the Telephone Company's employees or agents to enter the end user customer's designated premises at any reasonable hour for the purpose of installing, inspecting, repairing or removing the NID or drop associated with DSL Access Service.

The customer is responsible for providing all customer support, marketing, billing, ordering and repair to and for its end users. The customer is responsible for all dealings with end user customers.

The customer shall at all times be the customer of record with respect to all Services purchased hereunder and shall be responsible for payment to Telephone Company. Customer retains all responsibility for billing its end users and for any claim an end user may make concerning unauthorized billing.

DSL Rate Regulations

**DIGITAL SUBSCRIBER LINE ACCESS SERVICE – ROCK HILL TELEPHONE COMPANY,
FORT MILL TELEPHONE COMPANY, LANCASTER TELEPHONE COMPANY AND
CITIZENS TELEPHONE COMPANY D/B/A COMPORIUM COMMUNICATIONS**

Rate Elements

DSL Access Service arrangements are available in varying options for the applicable service class based on the Downstream and Upstream speed combinations chosen by the customer. Rates include monthly recurring charges and nonrecurring charges due at the time of installation. Rates and regulations for DSL Access Service are in addition to any rates and regulations that apply for the associated local exchange service line provided under the terms and conditions in the Telephone Company's general and/or local exchange service tariffs. A Term and Volume Discount Plan (TVDP) may be available for DSL Access Service.

The Telephone Company will not provision DSL Access Service if the Telephone Company has reasonably determined that (a) it is not technically feasible over existing facilities or (b) it will cause interference problems within the Telephone Company's network or other facilities.

Changes

All changes to existing DSL Access Service (e.g., a change of Network Service Provider and restoration of the DSL Access Service following a disconnect for non-payment of charges and/or a disconnect of the associated local exchange service line for any reason), other than changes involving DSL Network Reconfigurations and administrative activities, will be treated as a discontinuance of the existing service and an installation of a new service. A nonrecurring installation charge will apply per DSL Access Service line for this work activity.

The following administrative changes will be made without charge to the customer:

- Change of customer designated premises address when the change of address is not a result of a physical relocation of equipment,
- Change in billing data (name, address or contact name or telephone),
- Change of billing account number,
- Change of agency authorization that requires no changes to the Telephone Company's network,
- Change of customer contact name or telephone number, and
- Change of jurisdiction.

DSL Network Reconfiguration Charge

A DSL Network Reconfiguration Charge applies when the DSL Access Service customer requests the Telephone Company to modify the Telephone Company's network to: 1) accommodate a change in the DSL Access Service end user's existing IP address or 2) limit the data speed delivered over the end user's existing DSL Access Service line. This charge applies for each request per DSL Access Service line. The Telephone Company will bill the DSL Network Reconfiguration Charge to the Network Service Provider. The DSL Access Service Charge is set forth below.

Line Conditioning

Line conditioning is available, at no charge, and may be required if the facility will not accommodate DSL technology. This may include, but is not limited to, the removal of load coils, bridge taps and/or repeaters. The Telephone Company does not warrant that line conditioning will permit the provision of DSL technology.

Minimum Period

**DIGITAL SUBSCRIBER LINE ACCESS SERVICE – ROCK HILL TELEPHONE COMPANY,
FORT MILL TELEPHONE COMPANY, LANCASTER TELEPHONE COMPANY AND
CITIZENS TELEPHONE COMPANY D/B/A COMPORIUM COMMUNICATIONS**

The minimum service period for DSL Access Service provided on a month-to-month basis is one (1) month. If the DSL Access Service line is disconnected prior to the end of the minimum service period, the customer will be assessed all applicable monthly recurring rates for the remainder of the minimum service period.

Moves

A move involves a change in the physical location of one of the following:

- The Point of Termination at the DSL Access Service customer designated premises
- The DSL Access Service customer designated premises

The charges for the move are dependent on whether the move is to a new location within the same building or to a different building.

Moves Within the Same Building

When the move is to a new location within the same building, the charge for the move will be an amount equal to one half of the nonrecurring (i.e., installation) charge for the DSL Access Service affected. There will be no change in the minimum period requirements. This charge is in addition to the Access Order Charge as specified below.

Moves To a Different Building

Moves to a different building will be treated as a discontinuance and start of service and all associated nonrecurring charges will apply. New minimum period requirements will be established for the new services. The customer will also remain responsible for satisfying all outstanding minimum period charges for the discontinued service.

Nonrecurring Rates & Charges

DSL Service Order Charge, per order	\$82.00
Service Date Change Charge, per order	\$35.00
Design Change Charge, per order	\$35.00
Service Date Change Charge, per order	\$35.00
DSL Network Reconfiguration, per access service line	\$25.00
ADSL or SDSL Service Arrangement Installation, per service	\$49.95

**DIGITAL SUBSCRIBER LINE ACCESS SERVICE – ROCK HILL TELEPHONE COMPANY,
FORT MILL TELEPHONE COMPANY, LANCASTER TELEPHONE COMPANY AND
CITIZENS TELEPHONE COMPANY D/B/A COMPORIUM COMMUNICATIONS**

Monthly Recurring Rates & Charges

ADSL Arrangement (5.0 Mbps Down/512 Kbps Up)*	\$40.45
ADSL Arrangement (6.0 Mbps Down/636 Kbps Up)**	\$44.95
ADSL Arrangement (7.0 Mbps Down/768 Kbps Up)	\$53.95
ADSL Arrangement (9.0 Mbps Down/1.0 Mbps Up)	\$89.95

*Currently this is the only arrangement available in the Citizens Telephone Company service area.

**No longer available to new customers as of December 1, 2006.